

STANDARD CHARACTER MODULES

YMS 0802-01

8 CHAR x 2 LINE, 1/16 DUTY, 1/5 BIAS

EXTERNAL DIMENSION AND DISPLAY PATTERN

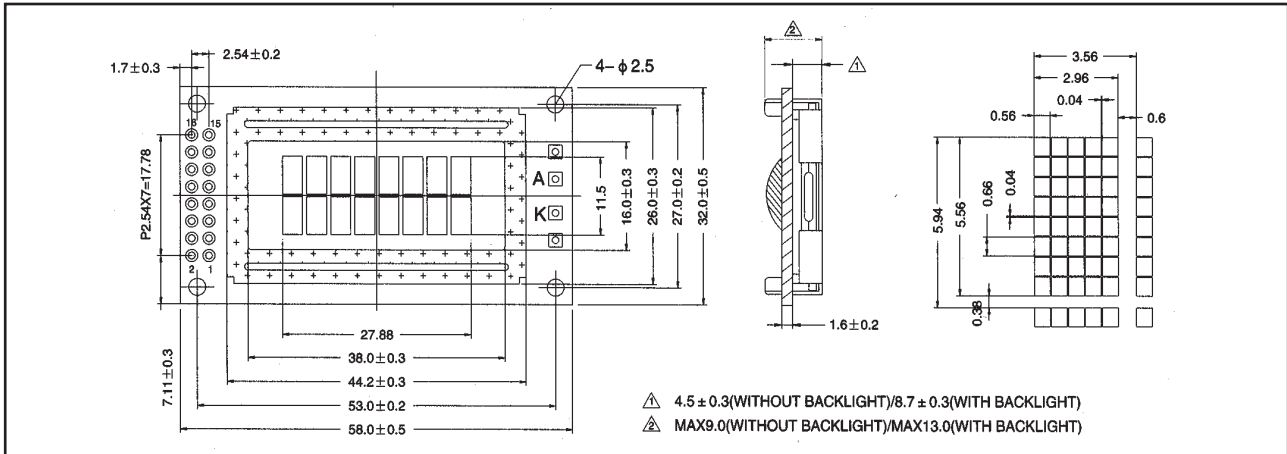

MECHANICAL DATA

ITEM	SPECIFICATION	UNIT
Module Size (W x H x T)	58.0 x 32.0 x 9.0/13.0	mm
Viewing Area (W x H)	38.0 x 16.0	mm
Character Font (W x H)	5.0 x 7.0 with cursor	dots
Character Size (W x H)	2.96 x 5.56	mm
Character Pitch (W x H)	3.56 x 5.94	mm
Dot Size (W x H)	0.56 x 0.66	mm

ABSOLUTE MAXIMUM RATINGS

PARAMETER	SYMBOL	MIN.	MAX.	UNIT
Supply Voltage Logic	$V_{DD} - V_{SS}$	-0.3	7.0	V
Supply Voltage Drive	$V_{DD} - V_{EE}$	-0.3	13.5	V
Input Voltage	V_{IN}	-0.3	$V_{DD} + 0.3$	V
Operating Temperature		See page 8		
Storage Temperature		See page 8		

PIN CONFIGURATION

PIN	SYMBOL	SIGNAL DESCRIPTION
1	V_{SS}	GND (0 V)
2	V_{DD}	Power Supply (+5.0V)
3	V_{EE}	Supply Voltage LCD Driver
4	RS	Register Select - LOW = Instruction, HIGH = DATA
5	R/W	Read / Write LOW = MPU to LCM, HIGH = LCM to MPU
6	E	Enable R/W = LOW: Data are talking over at falling edge R/W = HIGH: Data can be read at E = 1
7 to 14	DB ₀ to DB ₇	Data Bus - Software selectable 4 or 8 bit Mode
15	A	Anode of LED Unit
16	K	Cathode of LED Unit

ELECTRICAL CHARACTERISTICS, $T_a = 25^\circ\text{C}$

ITEM	SYMBOL	CONDITION	SPEC. VALUE			UNIT
			MIN.	TYP.	MAX.	
Supply Voltage (Logic)	$V_{DD} - V_{SS}$		4.5	5.0	5.5	V
Supply Current (Logic)	I_{DD}	$V_{DD} = 5V$		0.8	2.0	mA
Input Voltage	HIGH	V_{IH}	2.2		V_{DD}	V
	LOW	V_{IL}	-0.3		0.6	V
Output Voltage	HIGH	V_{OH}	$I_{OH} = 0.2mA$	2.4		V
	LOW	V_{OL}	$I_{OL} = 1.2mA$		0.4	V
LCD Operating Voltage	$V_{DD} - V_{EE}$	$V_{DD} = 5V$ $T_a = +25^\circ\text{C}$	4.5	4.7	5.0	V
Supply Current LCD Drive	I_{EE}			1.0	1.5	mA

Note (1): Value is high reliability type.

Note (2): Electro-Optical Characteristics: See page 5.

BLOCK DIAGRAM

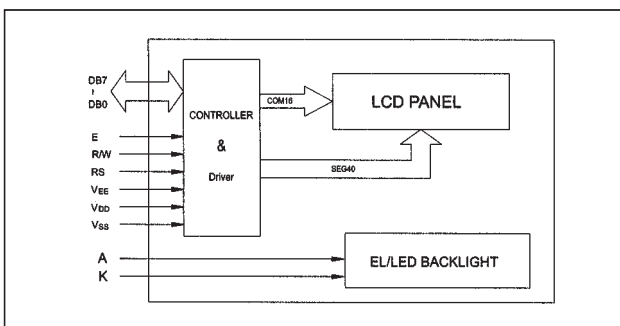

BACKLIGHTING CHARACTERISTICS, $T_a = 25^\circ\text{C}$, LED

ITEM	SYMBOL	CONDITION	SPEC. VALUE			UNIT
			MIN.	TYP.	MAX.	
Supply Voltage	V_{LED}		3.8	4.0	4.2	V
Power Consumption	P_{LED}	$I_F = 60mA$		240	600	mW
Luminous	I_v	$I_F = 60mA$	82	103		cd / m ²